



Spielkombination "Agelsberg" - Art.Nr. 31 2010 0553





SPK.Agelsberg
Art.Nr. 31 2010 0553
G m b H Fassung : 16.04.18
Konstr. : Markert
Technische Änderungen vorbehalten
☎ 09342/9649-0 📠 09342/9649-10

Gedruckt am 19.06.2020
Blatt 0
gez. :M.Knoll

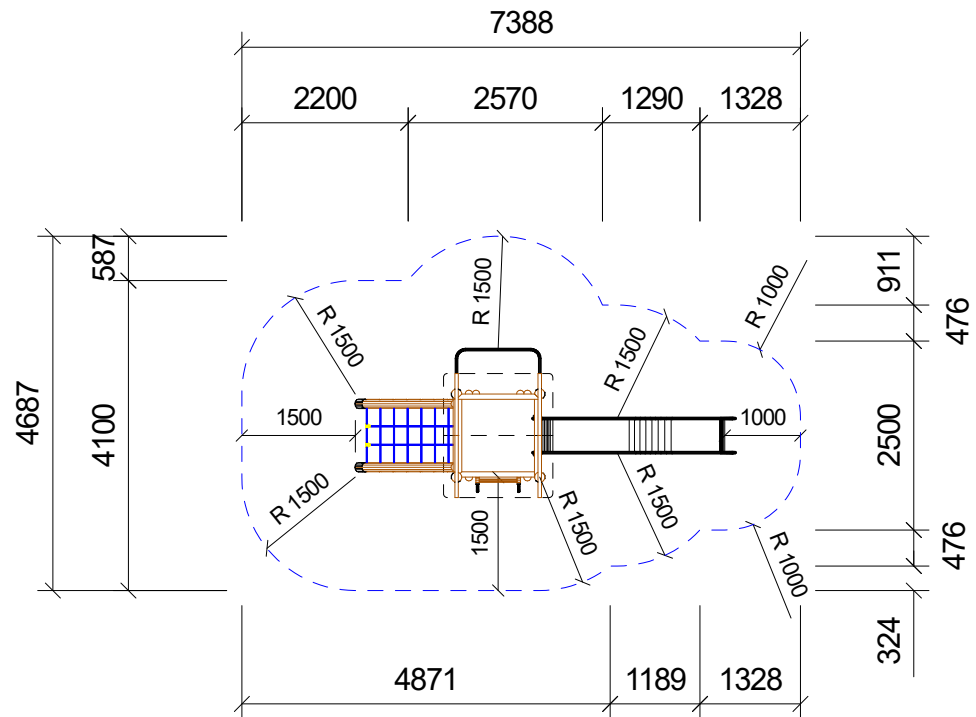

S.H. Spessart Holzgeräte GmbH
 97892 Kreuzwertheim
 Telefon: (0 93 42) 96 49-0
 Fax: (0 93 42) 96 49-10
 verkauf@spessart-holz.de

Art.Nr. 31 2010 0553
 Agelsberg
 Technische Änderungen vorbehalten
 © Spessartholz

Fassung : 14.05.2013
 gez. : Markert
 Alle Angaben in mm
 Maßstab : 1 = 100
 Blatt2

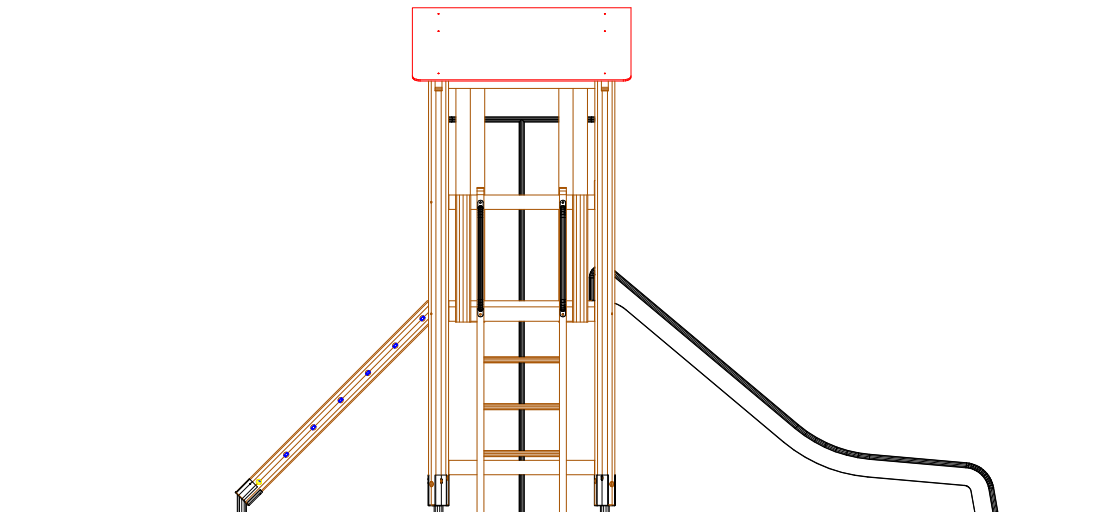
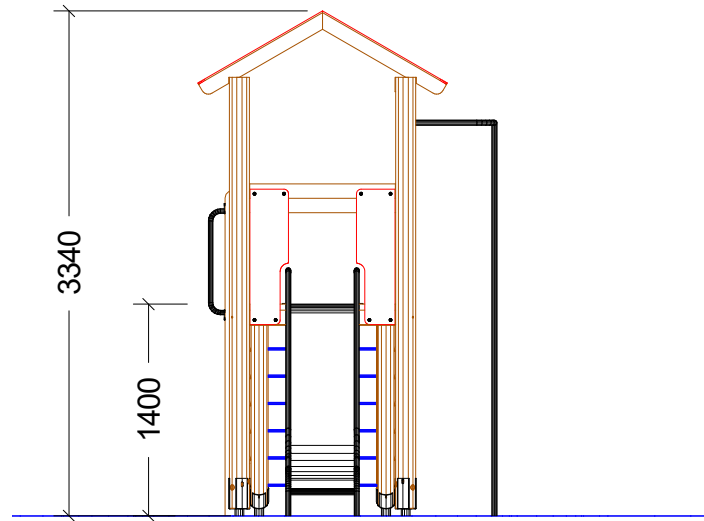

SPK.Agelsberg
 Art.Nr. 31 2010 0553
 G Fassung : 16.04.18
 m Konstr. : Markert
 b Technische Änderungen vorbehalten
 H
 ☎ 09342/9649-0 📠 09342/9649-10

Gedruckt am 19.06.2020
 M : 1 = 50 Blatt 1
 gez. :M.Knoll

Fundament-Plan SH-Bemaßung

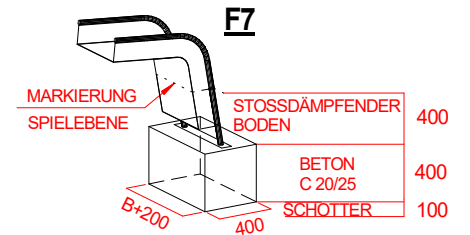
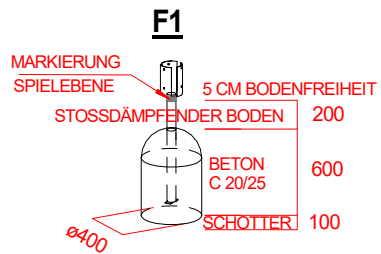
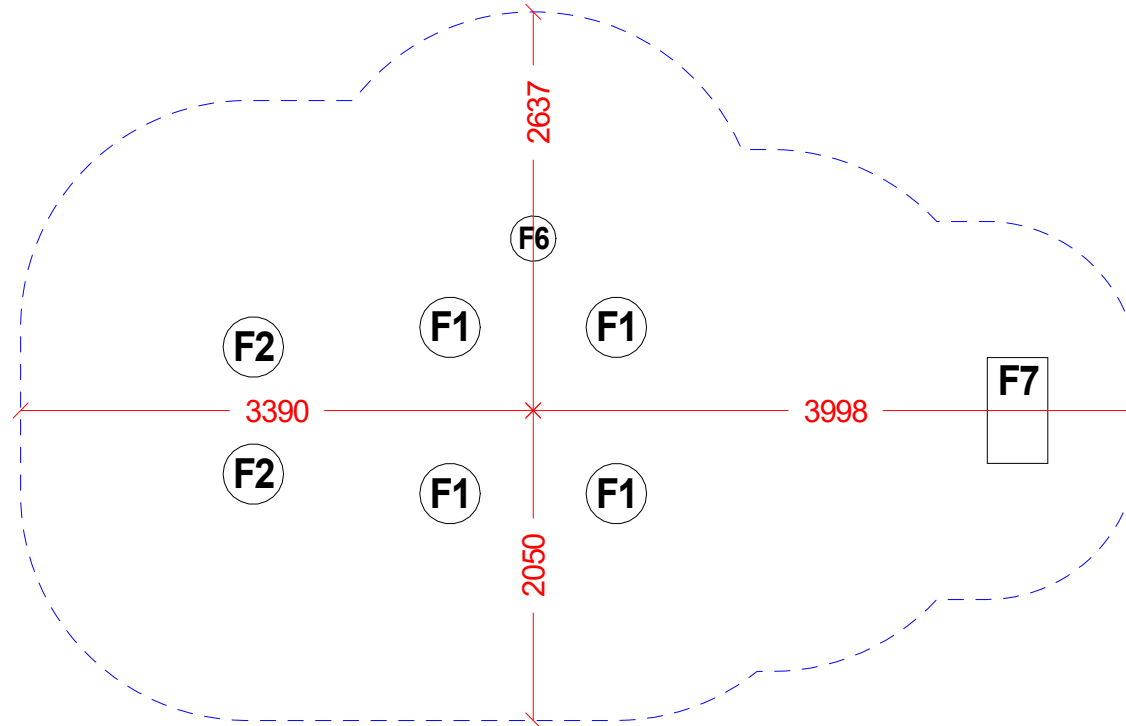
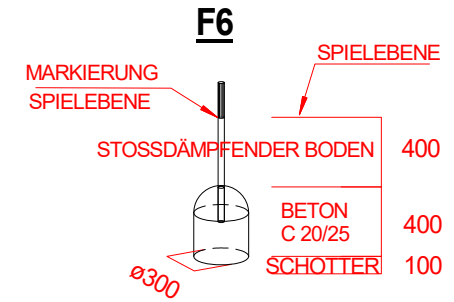
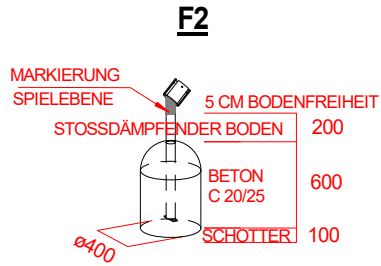

Stoßdämpfender Boden nach DIN 1176
(Tabelle siehe Wartungsanleitung)



S.H. Spessart Holzgeräte GmbH
97892 Kreuzwertheim
Telefon: (0 93 42) 96 49-0
Fax: (0 93 42) 96 49-10
verkauf@spessart-holz.de

Art.Nr. 31 2010 0553
Agelsberg
Technische Änderungen vorbehalten
© Spessartholz

Fassung : 14.05.2013
gez. : Markert
Alle Angaben in mm
Maßstab : 1 = 50
Blatt3

Fundament-Plan

F2

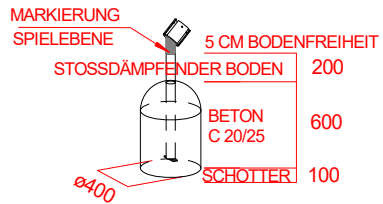

F6

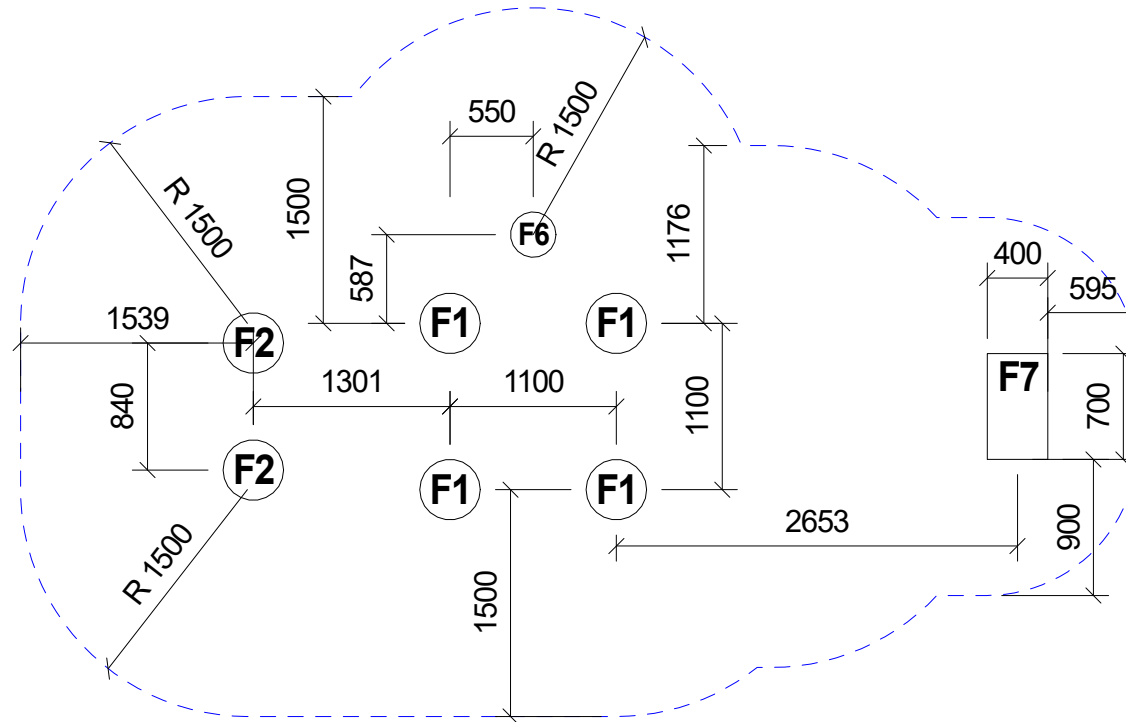
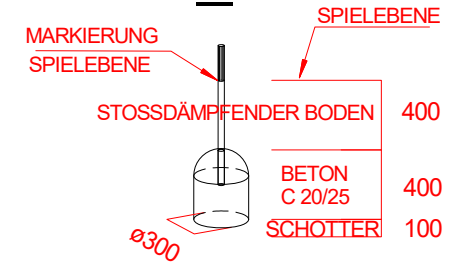

F1

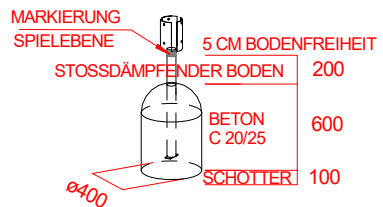

F7

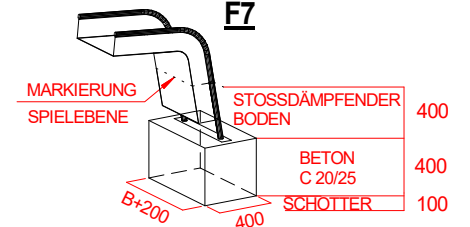

Stoßdämpfender Boden nach DIN 1176
(Tabelle siehe Wartungsanleitung)



S.H. Spessart Holzgeräte GmbH
97892 Kreuzwertheim
Telefon: (0 93 42) 96 49-0
Fax: (0 93 42) 96 49-10
verkauf@spessart-holz.de

Art.Nr. 31 2010 0553
Agelsberg
Technische Änderungen vorbehalten
© Spessartholz

Fassung : 14.05.2013
gez. : Markert
Alle Angaben in mm
Maßstab : 1 = 50
Blatt3

Pfostenlage
Handläufe-Brüstungen
Anbaugeräte

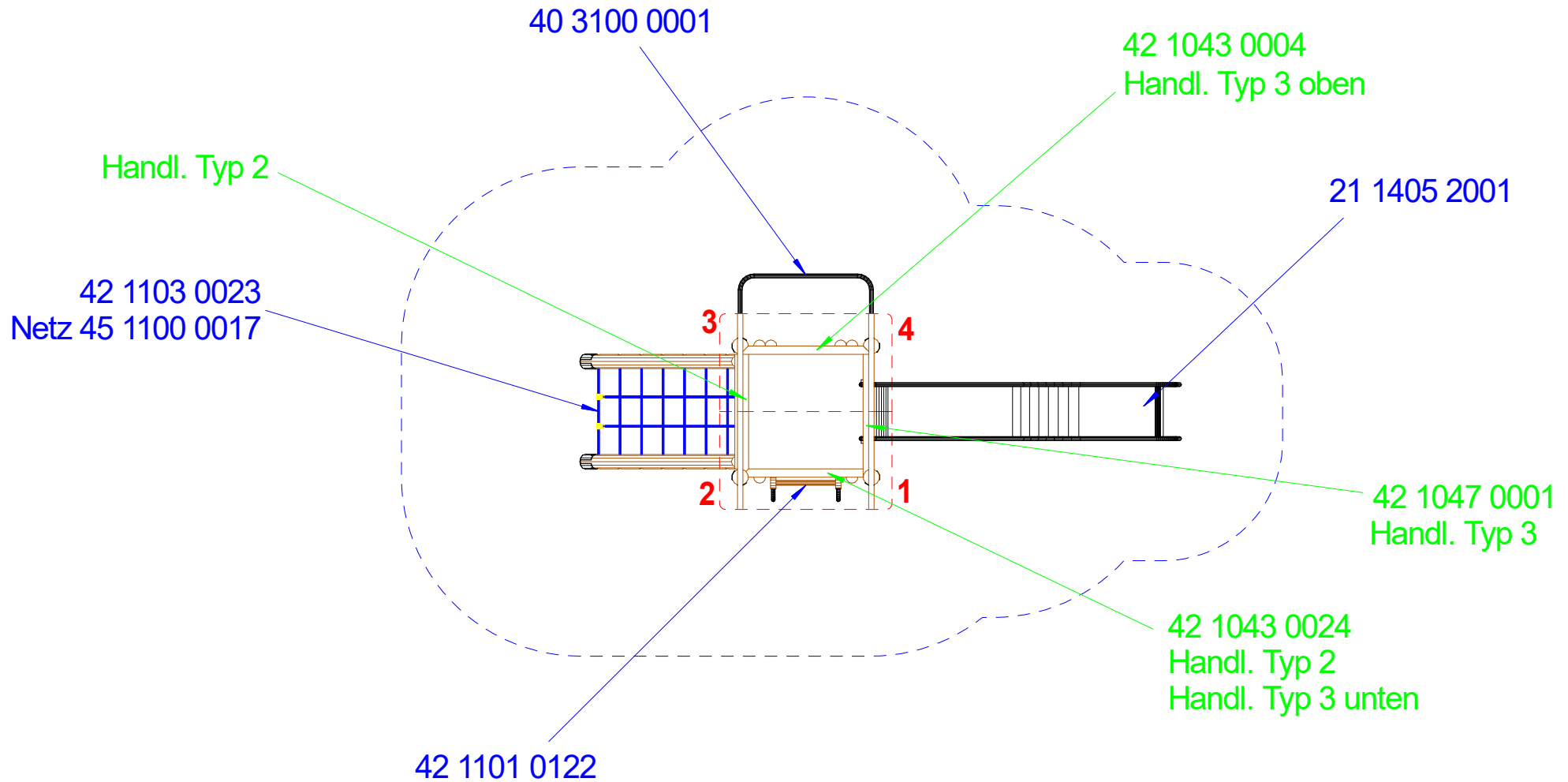

SPK.Agelsberg
 Art.Nr. 31 2010 0553
 G Fassung : 16.01.2019
 m Konstr. : Markert
 b Technische Änderungen vorbehalten
 H
 ☎ 09342/9649-0 📠 09342/9649-10

Gedruckt am 19.06.2020
 M : 1 = 50 Blatt 1
 gez. :M.Knoll